

National Technical Approval

Zulassungsstelle für Bauprodukte und Bauarten

Bautechnisches Prüfamt

Eine vom Bund und den Ländern
gemeinsam getragene Anstalt des öffentlichen Rechts

Mitglied der EOTA, der UEAtc und der WFTAO

Date:
14.11.2017

Reference:
| 31.1-1.14.4-48/17

Approval number:
Z-14.4-532

Period of qualification
From: **29 October 2017**
To: **29 October 2022**

Applicant:
EJOT Baubefestigungen GmbH
In der Stockwiese 35
57334 Bad Laasphe

Object of approval:
Solar Fastening System for mounting solar installations

The aforementioned object of approval is hereby granted national technical approval.
This national technical approval comprises nine pages and four attachments.
This national technical approval supersedes national technical approval no. Z-14.4-532 dated 29 October 2012. The product was granted national technical approval for the first time on 4 April 2007.

I. GENERAL PROVISIONS

1. The national technical approval is considered proof of the fitness for use or application of the object of approval for the purpose of the regional building regulations.
2. This decision does not replace any other permits, approvals or certificates prescribed by law for the execution of construction projects.
3. This decision is issued without prejudice to the rights of third parties, in particular private industrial property rights.
4. Manufacturers and distributors of the object of approval shall make available, notwithstanding any further regulations stipulated in the "Special provisions", copies of this ruling to the user of the approved object and shall point out that this ruling must be available wherever the approval object is applied or used. Copies shall also be provided to the authorities involved upon request.
5. This decision is allowed to be reproduced only in its entirety. Publication in the form of extracts is subject to the consent of the Deutsche Institut für Bautechnik (German Institute for Building Technology). Texts and drawings in brochures must not stand contradictory to this decision, translations must contain the note "Translation of the German original version not verified by the Deutschen Institut für Bautechnik".
6. This decision can be revoked. The provisions can be supplemented and changed at a later date, especially if this is required by new technical developments.
7. This decision also contains a general approval. The general approval contained in this decision is also deemed the national technical approval for the type of construction.
8. This decision relates to the information and documents presented by the applicant. Any modification to these basic principles is not covered by this decision and must be disclosed to the Deutschen Institut für Bautechnik without delay.

II. SPECIAL PROVISIONS

1. Object of approval and area of application

Object of approval are self-tapping screws with welded threaded pins made from corrosion resistant steel (Solar Fastening System) for the systematic load-transmitting connection of add-on parts (especially for elevated solar and photovoltaic installations or support profiles of solar installations) with substructures made from steel or wood. The Solar Fastening Systems are bolted through the crowns of profile panels or of profiled roof shells of sandwich panels made from steel or aluminium.

Illustrations of the individual Solar Fastening Systems with application examples are contained in Attachment 1.

This national technical approval governs the connections made with the Solar Fastening Systems for static and quasi-static effects according to DIN EN 1990:2010-12 in conjunction with DIN EN 1990/NA:2010-12.

2. Provisions for the Solar Fastening Systems

2.1 Characteristics and composition

2.1.1 Dimensions

The information given in Attachment 1 applies. Further information for the dimensions can be obtained from Deutsche Institut für Bautechnik.

2.1.2 Materials

The Solar Fastening Systems are manufactured from the corrosion-resistant steel 1.4301 or a different corrosion-resistant steel according to national technical approval no. Z-30.3-6, which is equivalent or higher quality in terms of corrosion resistance and mechanical properties.

2.1.3 Corrosion protection

The Solar Fastening Systems are corrosion resistant and therefore require no further corrosion protection.

2.2 Marking

The packing or the attachments to the delivery note for the Solar Fastening Systems stated in Section 2.1 must be marked by the manufacturer with the mark of conformity (C-mark) in accordance with the Mark of Conformity Regulations for the countries concerned. The marking may be applied only if the requirements in accordance with Section 2.3 are satisfied.

2.3 Confirmation of Compliance

2.3.1 Confirmation that the Solar Fastening Systems stated in Section 2.1 comply with the provisions of this national technical approval must be issued by a recognised supervisory body in accordance with the following provisions for each manufacturing plant, with a certificate of compliance from the manufacturer on the basis of an in-plant production control and a compliance certificate from a supervisory body accredited for this purpose.

For the issuing of the certificate of compliance and the external control, including the product inspections to be carried out, the manufacturer of the Solar Fastening Systems stated in Section 2.1 must engage a certifying body and a supervisory body accredited for this purpose.

The manufacturer must submit the certificate of compliance by marking the Solar Fastening Systems stated in Section 2.1 with the Mark of Conformity (C-mark) making reference to the purpose for use.

The certifying body shall submit a copy of the certificate of conformity it has issued to the Deutsches Institut für Bautechnik for information.

The approval principles of the Deutsches Institut für Bautechnik for the "Verification of conformity for connecting elements in a lightweight metal construction" (see issue 6/1999 of "DIBt Mitteilungen") apply for the scope, method and frequency of in-plant production control and external monitoring processes.

2.3.2 In-plant production control

Every manufacturing plant shall set up and implement an in-plant production control. In-plant production control means continuous monitoring of production to be performed by the manufacturer, by means of which the latter ensures that the Solar Fastening Systems produced by them comply with this national technical approval.

In addition to the inspections stated in Section 2.3.1, the in-plant production control is to include at least the measures listed below:

- For each production unit, bending tests must be carried out on three Solar Fastening Systems. The welded threaded pins must achieve a bending angle of at least 45° without breaking.
- For the measures to be carried out as part of the in-plant production control, the following minimum values of the mechanical properties shall apply:
Minimum breaking torque 29.40 Nm to DIN EN ISO 3506-4 (Hardness class 25H)
Bending loading capacity 33.35 Nm

The results of the in-plant production control must be recorded and evaluated. The records must contain at least the following information:

- designation of the construction product and/ the base material and of the components
- type of the control or inspection
- date of manufacture and date of inspection of the Solar Fastening System and/or the base material or of the components
- result of the controls and inspections and comparison with the requirements of the Deutschen Institut für Bautechnik
- signature of the person responsible for in-plant production control

The records must be kept for at least five years and submitted to the supervisory body engaged for the external control procedure. These records must be submitted to the Deutsche Institut für Bautechnik and the responsible highest level construction supervisory authority on request.

In case of unsatisfactory inspection results, the manufacturer must implement the measures required to rectify the defect immediately. Solar Fastening Systems that do not fulfil requirements must be handled in such a way that mix-ups with conformities are excluded. After rectification of the defect – where technically possible and required as proof that the defect has been rectified – the corresponding inspection must be repeated immediately.

2.3.3 External control procedure

In every manufacturing plant, the plant and the in-plant quality control process must be reviewed regularly, at least once a year, by means of an external control procedure.

As part of the external control procedure, an initial inspection of the Solar Fastening Systems stated in Section 2.1 must be carried out and specimens can also be taken for spot checks. The sampling and inspection procedures are the responsibility of the accredited external supervisory body.

The results of the certification and external monitoring must be kept for at least five years. The certification body and/or supervisory body must submit these to the Deutsche Institut für Bautechnik and the responsible highest level construction supervisory authority on request.

3. Provisions for use of the object of approval

3.1 Planning

If the Solar Fastening Systems are loaded transverse to the profile panels or sandwich panels, the profile panels or sandwich panels must be fastened to the substructure at the same height in the adjacent wave troughs (see Fig. 1). These fastenings must be designed such that they transfer the shear force from the Solar Fastening Systems in the substructure. In case of transverse forces from the Solar Fastening Systems in the longitudinal direction of the profile panels or sandwich panels, remote connections between the corresponding profile panels and the substructure can be used to transfer the load.

The edge distance of the Solar Fastening Systems in the clamping direction of the sandwich panels must be a minimum of 250 mm and the distance of the Solar Fastening Systems in the clamping direction between one other must be a minimum of 500 mm. A fastening in the edge ribs is not permitted.

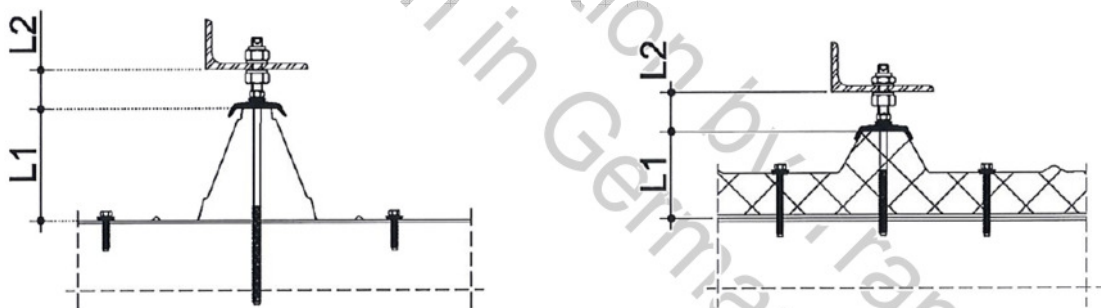

Figure 1

3.1.1 Dimensions of the profile panels, sandwich panels and substructures

3.1.1.1 Profile panels

The nominal sheet thickness of the outer protective layer in the area of the fastenings is 0.4 mm for steel and 0.5 mm for aluminium.

3.1.1.2 Sandwich panels

The nominal sheet thickness of the outer protective layer in the area of the fastenings is 0.4 mm for steel and 0.5 mm for aluminium.

3.1.1.3 Substructures

The nominal sheet thickness for steel substructures in the area of the fastenings is 1.5 mm.

3.1.2 Materials of the profile panels, sandwich panels and substructures

3.1.2.1 Profile panels and protective layers of sandwich panels

The raw materials of profile panels or protective layers via which fastenings are made must meet the following requirements:

$R_m \geq 390 \text{ N/mm}^2$ for profile panels from steel and
 $R_m \geq 195 \text{ N/mm}^2$ for profile panels from aluminium.

3.1.2.2 Core material of the sandwich panels, via which the Solar Fastening Systems are mounted

The Solar Fastening Systems are allowed to be used for sandwich panels with polyurethane cores.

The core material must meet the following minimum requirements:

Tensile strength of the core material with protective layer $f_{ct} \geq 0.06 \text{ N/mm}^2$

Tensile shear strength of the core material $f_{cv} \geq 0.05 \text{ N/mm}^2$

For the sandwich panels, proof of usability must have been issued by the building authorities.

3.1.2.3 Substructure

For use of Solar Fastening System JZ3-SB-8,0 x L, the substructure must consist of steel grades S235 to DIN EN 10025-2:2005-04 or S280GD or S320GD to DIN EN 10346:2015-10. For use of Solar Fastening Systems JT3-SB-3-8,0 x L and JT6-SB-3-8,0 x L, the substructure must consist of steel grades S235 or S275 to DIN EN 10025-2:2005-04 or S280GD to S450GD and HX300LAD to HX460LAD to DIN EN 10346:2015-10.

The use of Solar Fastening System JA3-SB-8,0 x L and JA3-SB-10,0 x L is intended for substructures from coniferous wood, at least strength grade C24 to DIN 1052:2008-12.

3.2 Dimensioning

3.2.1 General

The verification concept stated in DIN EN 1990:2010-12 in combination with DIN EN 1990/NA:2010-12 applies.

3.2.2 Characteristic values for load capacity

3.2.2.1 Characteristic values for tension and compression capacity $N_{R,k}$
Solar Fastening System JZ3-SB-8,0 x L, JT3-SB-3-8,0 x L and JT6-SB-3-8,0 x L:

Table 1

	Thickness of the substructure [mm]			
	1.5	2.00	3.00	≥ 4
$N_{R,k}$ [kN]	2.20	3.40	5.80	6.80

For intermediate values for the thickness of the substructure, $N_{R,k}$ is to be selected for the minimal part thickness.

With thin-walled ($t_{II} \leq 2.00 \text{ mm}$), asymmetric substructures (e.g. C- or Z-profile), the characteristic load capacity values $N_{R,k}$ are to be reduced by 30 %.

Solar Fastening System JA3-SB-8.0 X L:

$$N_{R,k} = 0.0686 \cdot k_{mod} \cdot l_{ef} \quad [\text{kN/mm}]$$

$$\text{where } l_{ef} \geq 32 \text{ mm and } l_{ef} \leq 0.6 \cdot L$$

or in accordance with Attachment 2, Table 4

- l_{ef} - Effective installation depth into the timber substructure
- k_{mod} - Modification factor to DIN 1052:2004-08, Attachment F
- L - Length of the screw in accordance with Attachment 1

Solar Fastening System JA3-SB-10.0 x L:

$$N_{R,k} = 0.0858 \cdot k_{mod} \cdot l_{ef} \quad [\text{kN/mm}]$$

$$\text{where } l_{ef} \geq 40 \text{ mm and } l_{ef} \leq 0.6 \cdot L$$

or in accordance with Attachment 2, Table 4

Solar Fastening System JZ3-SB-8.0 x L, JT3-SB-3-8.0 x L and JT6-SB-3-8.0 x L and JA3-SB-8.0 x L and JA3-SB-10.0 x L:

For compressive stress, the Solar Fastening Systems must also be inspected for buckling.

Characteristic value of the compression capacity for buckling:

$$N_{R,k} = 1.1 \cdot (\kappa \cdot N_{pl,d})$$

$\kappa \cdot N_{pl,d}$ see Attachments 3 and 4, Tables 5 to 7

The lower value for $N_{R,k}$ is decisive.

3.2.2.2 Characteristic values for the shear force load capacity $V_{R,k}$

$$V_{R,k} = \min \left\{ \frac{F_{L,k} \cdot L1}{(L1 + L2)}; \frac{M_{pl,k}}{L2} \right\}$$

$L1$ and $L2$ see Attachment 1

Table 2 Values for $F_{L,k}$ in kN

t_N [mm]	profile panels or outer skin made of steel $R_m \geq 195 \text{ N/mm}^2$					profile panels or outer skin made of aluminium $R_m \geq 195 \text{ N/mm}^2$		
	0,40*	0,55*	0,63*	0,75	$\geq 1,0$	0,50	0,60	$\geq 0,70$
$F_{L,k}$ [kN]	0,64*	1,63*	1,86*	1,90	2,61	0,53	0,82	1,11

* Intermediate values must be linearly interpolated

t_N - Nominal plate thickness of the profile panels outer skin of the sandwich panels

$M_{pl,k} = 33.35 \text{ Nm}$ for Solar Fastening Systems JZ3-SB-8.0 x L, JT3-SB-3-8.0 x L and JT6-SB-3-8.0 x L

$M_{pl,k} = 40.66 \text{ Nm}$ for Solar Fastening System JA3-SB-8,0 x L and JA3-SB-10.0 x L

3.2.3 Rated values for load capacity

For calculating the load capacity rated values from the characteristic values:

$$N_{R,d} = \frac{N_{R,k}}{\gamma_M}$$

$$V_{R,d} = \frac{V_{R,k}}{\gamma_M}$$

where $\gamma_M = 1.33$

3.2.4 Combined stress from tensile or compressive forces and shear forces

For combined stress through the rated values of the acting tensile forces N and shear forces V, no reduction is required. For simultaneous effects of compressive and shear forces, the following simplified proof of flexural buckling must also be furnished:

$$\frac{N}{\kappa \cdot N_{pl,d}} + \frac{V \cdot L_2}{M_{pl,d}} \leq 1.0$$

$\kappa \cdot N_{pl,d}$ see Attachments 3 and 4, Tables 5 to 7

$$M_{pl,d} = \frac{M_{pl,k}}{\gamma_M} \quad \gamma_M = 1.1$$

$M_{pl,d} = 30.3 \text{ Nm}$ for Solar Fastening System JZ3-SB-8.0 x L, JT3-SB-3-8.0 x L and JT6-SB-3-8.0 x L

$M_{pl,d} = 37.0 \text{ Nm}$ for Solar Fastening System JA3-SB-8.0 x L and JA3-SB-10.0 x L

3.3 Design

The structural design of Solar Fastening Systems is set out in Attachment 1.

It must be ensured through the design that no contact corrosion can occur and that no compressive and tensile forces are introduced in the profile panels and sandwich panels. The profile panels or sandwich panels and the substructure must be pre-drilled in accordance with the Attachments in Table 3.

Table 3 Pre-drilling diameter in mm

Solar Fastening Systems	Thickness of the substructure: [mm]					
	Steel				Timber	
	1.5 ... < 5.0	1.5 ... < 5.0	1.5 ... < 5.0	≥ 10	≥ 32	≥ 40
JZ3-SB-8.0 x L JT3-SB-3-8.0 x L JT6-SB-3-8.0 x L	6.8	7.0	7.2	7.4	-	-
JA3-SB-8.0 x L	-	-	-	-	5.5	5.5
JA3-SB-10.0 x L	-	-	-	-		7.0

The Solar Fastening Systems must be introduced at right-angles to the part surface, in order to ensure a faultless bearing, where required rain-proof, fastening.

When mounting Solar Fastening Systems via sandwich panels, it must be ensured that the roof shells are not excessively deformed.

The Solar Fastening Systems, including the elements to be fastened, must be stored and mounted in a clean, dry and grease-free condition.

National technical approval

No. Z-14.4-532

Page 9 of 9 | 14. November 2017

An instruction for the design of the Solar Fastening Systems must be prepared by the manufacturer and delivered to the construction company. The design instructions must include information on the screwing device and for setting the writing instrument. The use of impact screwdrivers is not permitted.

Only companies with the experience required are allowed to make connections via Solar Fastening Systems, unless the installation staff are instructed by specialists from companies experienced in this field.

Confirmation that the design of the fastening complies with the provisions of this national technical approval must be provided by the construction company.

Andreas Schult

Head of division

English Translation by Transline -
Original Version in German Language

JA3-SB-8.0 x L and JA3-SB-10.0 x L

for wooden substructures

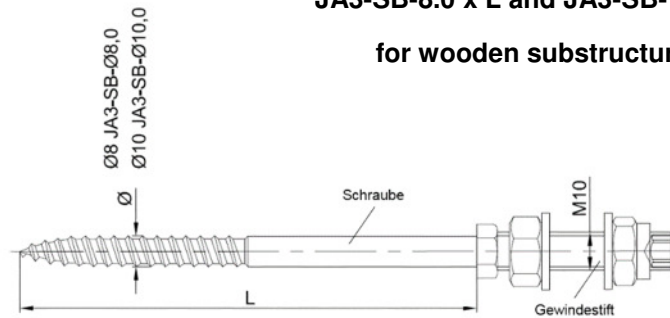

JT3-SB-3-8.0 x L and JT6-SB-3-8.0 x L for steel substructures

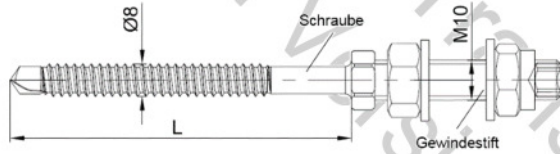

JZ3-SB-8.0 x L

for steel substructures

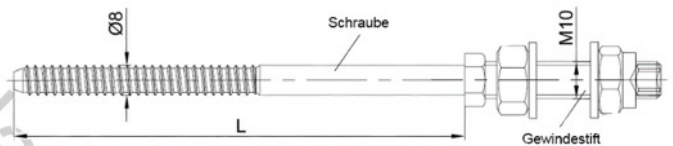

Examples for use of Solar Fastening System JZ3-SB-8.0 with trapezoidal profile panels and sandwich panels on steel substructures

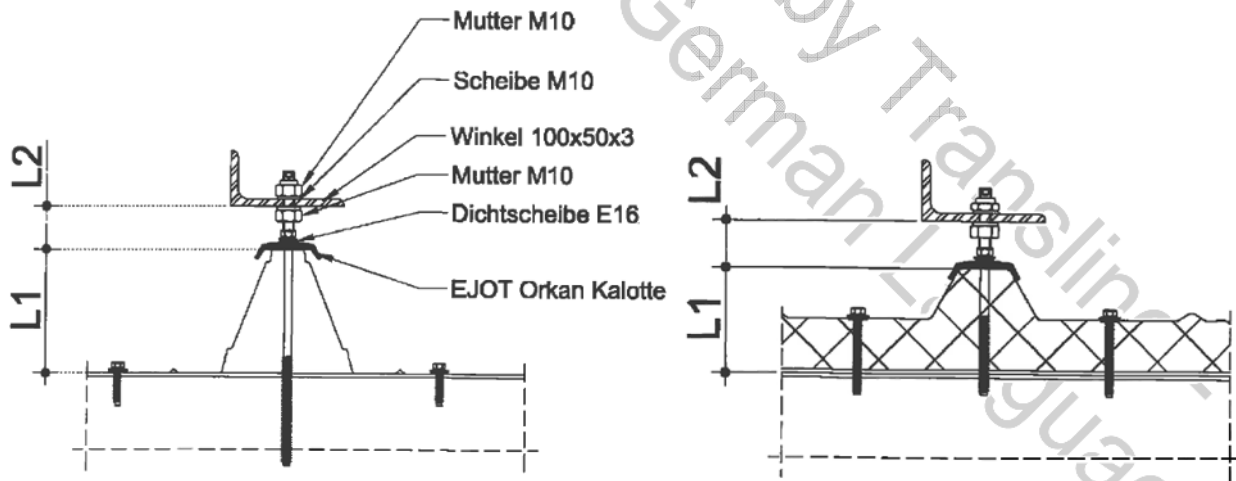

L1 – Distance between the upper edge of the substructure into which the Solar Fastening System is bolted (this does not necessarily have to be the substructure for the the profile panels and can be located lower) and upper edge of the profile panel

Solar Fastening System for mounting solar installations

Solar Fastening System JZ3-SB-8.0 x L, JA3-SB-8.0 x L, JA3-SB-10.0 x L,
JT3-SB-3-8.0 x L, JT6-SB-3-8.0 x L

Attachment 1

Table 4 Characteristic values for load capacity $N_{R,k}$ in kN regarding pull-out for JA3-SB-8.0 x L and JA3-SB-10 x L made of softwood in the strength class C24, usage class 2

Characteristic values for load capacity $N_{R,k}$ for Solar Fastening Systems JA3-SB-8.0 x L and JA3-SB-10.0 x L ($d = 10$) depending on the accumulated load duration and screw in depth										
Installation depth l_{ef} in mm	permanent $k_{mod} = 0.6$ more than 10 years (generally self-weight)		long $k_{mod} = 0.7$ 6 month to 10 years		medium $k_{mod} = 0.8$ 1 week to 6 month (generally snow load)		short $k_{mod} = 0.9$ less than a week (generally wind load)		Very short $k_{mod} = 1.1$ less than a minute	
	$d = 8.0$	$d = 10$	$d = 8.0$	$d = 10$	$d = 8.0$	$d = 10$	$d = 8.0$	$d = 10$	$d = 8.0$	$d = 10$
	32	1.32	-	1.54	-	1.76	-	1.98	-	2.42
40	1.65	2.06	1.92	2.40	2.20	2.74	2.47	3.09	3.02	3.77
45	1.85	2.32	2.16	2.70	2.47	3.09	2.78	3.47	3.40	4.25
48	1.98	2.47	2.31	2.88	2.63	3.29	2.96	3.70	3.62	4.53
50	2.06	2.57	2.40	3.00	2.74	3.43	3.09	3.86	3.77	4.72
56	2.31	2.88	2.69	3.36	3.07	3.84	3.46	4.32	4.23	5.28
60	2.47	3.09	2.88	3.60	3.29	4.12	3.70	4.63	4.53	5.66
64	2.63	3.29	3.07	3.84	3.51	4.39	3.95	4.94	4.83	6.04
70	2.88	3.60	3.36	4.20	3.84	4.80	4.32	5.40	5.28	6.60
72	2.96	3.70	3.46	4.32	3.95	4.94	4.45	5.56	5.43	6.79
80	3.29	4.12	3.84	4.80	4.39	5.49	4.94	6.17	6.04	7.55
85	3.50	4.37	4.08	5.10	4.67	5.83	5.25	6.56	6.41	8.02
88	3.62	4.53	4.23	5.28	4.83	6.04	5.43	6.79	6.64	8.30
90	3.70	4.63	4.32	5.40	4.94	6.17	5.56	6.95	6.79	8.49
96	3.95	4.94	4.61	5.76	5.27	6.59	5.93	7.41	7.24	9.06
100	4.12	5.15	4.80	6.00	5.49	6.86	6.17	7.72	7.55	9.43
104	4.28	5.35	4.99	6.24	5.71	7.13	6.42	8.03	7.85	9.81
110	4.53	5.66	5.28	6.60	6.04	7.55	6.79	8.49	8.30	10.38
112	4.61	5.76	5.38	6.72	6.15	7.68	6.92	8.64	8.45	10.57
120	4.94	6.17	5.76	7.20	6.59	8.23	7.41	9.26	9.06	11.32

Solar Fastening System for mounting solar installations

Table 4
Characteristic values for load capacity $N_{R,k}$ in kN for **JA3-SB-8.0 x L** and **JA3-SB-10 x L**

Attachment 2

Table 5 $\kappa \cdot N_{pl,d}$ in kN for the Solar Fastening System **JA3-SB-8.0 x L**

L ₁ in mm	L ₂ in mm							
	30	40	50	60	70	80	90	100
70	6.14	5.22	4.52	3.96	3.52	3.16	2.86	2.60
80	5.28	4.52	3.93	3.46	3.08	2.77	2.52	2.30
90	4.59	3.95	3.45	3.05	2.73	2.46	2.24	2.05
100	4.02	3.48	3.06	2.72	2.44	2.21	2.01	1.84
110	3.55	3.09	2.73	2.44	2.19	1.99	1.82	1.67
120	3.15	2.77	2.45	2.20	1.98	1.81	1.65	1.52
130	2.82	2.49	2.22	1.99	1.81	1.65	1.51	1.40
140	2.54	2.25	2.02	1.82	1.65	1.51	1.39	1.29
150	2.29	2.05	1.84	1.67	1.52	1.39	1.28	1.19
160	2.08	1.87	1.69	1.53	1.40	1.29	1.19	1.10
170	1.90	1.71	1.55	1.41	1.30	1.19	1.11	1.03
180	1.74	1.57	1.43	1.31	1.20	1.11	1.03	0.96
190	1.60	1.45	1.33	1.22	1.12	1.04	0.96	0.90
200	1.47	1.34	1.23	1.13	1.05	0.97	0.90	0.84

Table 6 $\kappa \cdot N_{pl,d}$ in kN for the Solar Fastening System **JA3-SB-10.0 x L**

L ₁ in mm	L ₂ in mm							
	30	40	50	60	70	80	90	100
70	14.30	12.04	10.29	8.90	7.79	6.89	6.14	5.51
80	12.40	10.52	9.04	7.87	6.92	6.14	5.50	4.96
90	10.83	9.26	8.01	7.01	6.20	5.52	4.96	4.49
100	9.53	8.21	7.15	6.29	5.58	5.00	4.51	4.09
110	8.44	7.32	6.42	5.67	5.06	4.55	4.12	3.75
120	7.53	6.57	5.79	5.15	4.61	4.16	3.78	3.45
130	6.75	5.93	5.26	4.69	4.22	3.82	3.48	3.18
140	6.08	5.38	4.79	4.30	3.88	3.52	3.22	2.95
150	5.51	4.90	4.38	3.95	3.58	3.26	2.98	2.74
160	5.01	4.48	4.03	3.64	3.31	3.02	2.78	2.56
170	4.57	4.11	3.71	3.37	3.07	2.81	2.59	2.39
180	4.17	3.78	3.43	3.13	2.86	2.63	2.42	2.24
190	3.86	3.50	3.18	2.91	2.67	2.46	2.27	2.11
200	2.56	3.24	2.96	2.71	2.49	2.30	2.13	1.98

Solar Fastening System for mounting solar installations

Attachment 3

Table 5 $\kappa \cdot N_{pl,d}$ in kN for the Solar Fastening System **JA3-SB-8.0 x L**

Table 6 $\kappa \cdot N_{pl,d}$ in kN for the Solar Fastening System **JA3-SB-10.0 x L**

Table 7 $\kappa \cdot N_{pl,d}$ in kN for Solar Fastening Systems
JZ3-SB-8.0 x L, JT3-SB-3-8.0 x L and JT6-SB-3-8.0 x L

L ₁ in mm	L ₂ in mm							
	30	40	50	60	70	80	90	100
70	8.32	7.15	6.22	5.47	4.86	4.36	3.94	3.58
80	7.27	6.27	5.47	4.83	4.30	3.87	3.50	3.19
90	6.39	5.53	4.85	4.30	3.84	3.46	3.14	2.87
100	5.65	4.92	4.33	3.85	3.45	3.12	2.84	2.60
110	5.02	4.37	3.87	3.47	3.12	2.83	2.58	2.37
120	4.49	3.95	3.51	3.14	2.84	2.58	2.36	2.17
130	4.03	3.57	3.19	2.86	2.59	2.36	2.17	2.00
140	3.64	3.24	2.90	2.62	2.38	2.18	2.00	1.85
150	3.30	2.95	2.66	2.41	2.19	2.01	1.85	1.71
160	3.01	2.70	2.44	2.22	2.03	1.86	1.72	1.59
170	2.75	2.48	2.25	2.05	1.88	1.73	1.60	1.49
180	2.53	2.27	2.08	1.90	1.75	1.61	1.50	1.39
190	2.33	2.12	1.93	1.77	1.63	1.51	1.40	1.31
200	2.15	1.96	1.80	1.65	1.53	1.41	1.32	1.23

Solar Fastening System for mounting solar installations

Attachment 4

Table 7 $\kappa \cdot N_{pl,d}$ for Solar Fastening Systems
JZ3-SB-8.0 x L, JT3-SB-3-8.0 x L and JT6-SB-3-8.0 x L